



# LCD Module Technical Specification

First Edition  
Oct 3, 2002

Final Revision  
\*\*\*\*\*

Type No. **F-51553GNBJ-LW-AB**

Approved by (Production Div.)

Checked by (Quality Assurance Div.)

Checked by (ACI Engineering Div.)

Prepared by (Production Div.)

## Table of Contents

1. General Specifications .....	2
2. Electrical Specifications .....	3
3. Optical Specifications .....	12
4. I/O Terminal .....	14
5. Test .....	17
6. Appearance Standards .....	18
7. Code System of Production Lot .....	22
8. Type Number .....	22
9. Applying Precautions .....	22
10. Precautions Relating Product Handling .....	23
11. Warranty .....	24

## Revision History

Rev.	Date	Page	Comment

## 1. General Specifications

Operating Temp.	:	min. -20°C ~max. 70°C
Storage Temp.	:	min. -30°C ~max. 85°C
Dot Pixels	:	128 (W) × 64 (H) dots
Dot Size	:	0.48 (W) × 0.48 (H) mm
Dot Pitch	:	0.50 (W) × 0.50 (H) mm
Viewing Area	:	66.8 (W) × 35.5 (H) mm
Outline Dimensions	:	89.7 (W) × 49.8* (H) × 6.0 (D) mm * Without FPCUV
Weight	:	33.0g max.
LCD Type	:	NTD-21558 ( STN / Blue-mode / Transmissive )
Viewing Angle	:	6:00
Data Transfer	:	8-bit parallel data transfer Serial data transfer
Backlight	:	LED Backlight / White
Drawings	:	Dimensional Outline UE-311234A

## 2. Electrical Specifications

### 2.1. Absolute Maximum Ratings

GND=0V

Parameter	Symbol	Conditions	Min.	Max.	Units
Supply Voltage (Logic)	V <sub>DD-GND</sub>	-	-0.3	7.0	V
Supply Voltage (Booster Circuit)	V <sub>DD-GND</sub>	-	-6.0	+0.3	V
Supply Voltage 1 (LCD Drive)	V <sub>5</sub> , V <sub>OUT</sub>	-	-18.0	+0.3	V
Input Voltage	V <sub>IN</sub>	-	-0.3	V <sub>DD</sub> +0.3	V

### 2.2. DC Characteristics

T<sub>a</sub>=25°C, GND=0V

Parameter	Symbol	Conditions	Min.	Typ.	Max.	Units
Supply Voltage (Logic)	V <sub>DD-GND</sub>	With Triple	4.5	-	5.5	V
		With Quad	2.7	-	3.3	
Supply Voltage (LCD Drive)	V <sub>DD-V5</sub>	Shown in 3.1				V
"High" Level Input Voltage	V <sub>IH</sub>	-	0.8 × V <sub>DD</sub>	-	V <sub>DD</sub>	V
"Low" Level Input Voltage	V <sub>IL</sub>	-	GND	-	0.2 × V <sub>DD</sub>	V
"High" Level Output Voltage	V <sub>OH</sub>	I <sub>OH</sub> =-0.1mA	0.8 × V <sub>DD</sub>	-	V <sub>DD</sub>	V
"Low" Level Output Voltage	V <sub>OL</sub>	I <sub>OL</sub> =0.1mA	GND	-	0.2 × V <sub>DD</sub>	V
Supply Current	I <sub>DD</sub>	V <sub>DD-GND</sub> =5.0V	-	0.84	1.26	mA

## 2.3.AC Characteristics

### 2.3.1.Read/Write Operation Sequence (80 series CPU)

$V_{DD}=5.0V\pm 10\%$

Parameter	Symbol	Min.	Max.	Units	
Address Setup Time	$t_{AW8}$	0	-	ns	
Address Hold Time	$t_{AH8}$	0	-	ns	
System Cycle Time	$t_{CYC8}$	166	-	ns	
Control Low Pulse Width	WRITE	$t_{CCLW}$	30	-	ns
	READ	$t_{CCLR}$	70	-	ns
Control High Pulse Width	WRITE	$t_{CCHW}$	30	-	ns
	READ	$t_{CCHR}$	30	-	ns
Data Setup Time	$t_{DS8}$	30	-	ns	
Data Hold Time	$t_{DH8}$	10	-	ns	
RD Access Time	$t_{ACC8}$	-	70	ns	
Output Disable Time	$t_{OH8}$	5	50	ns	

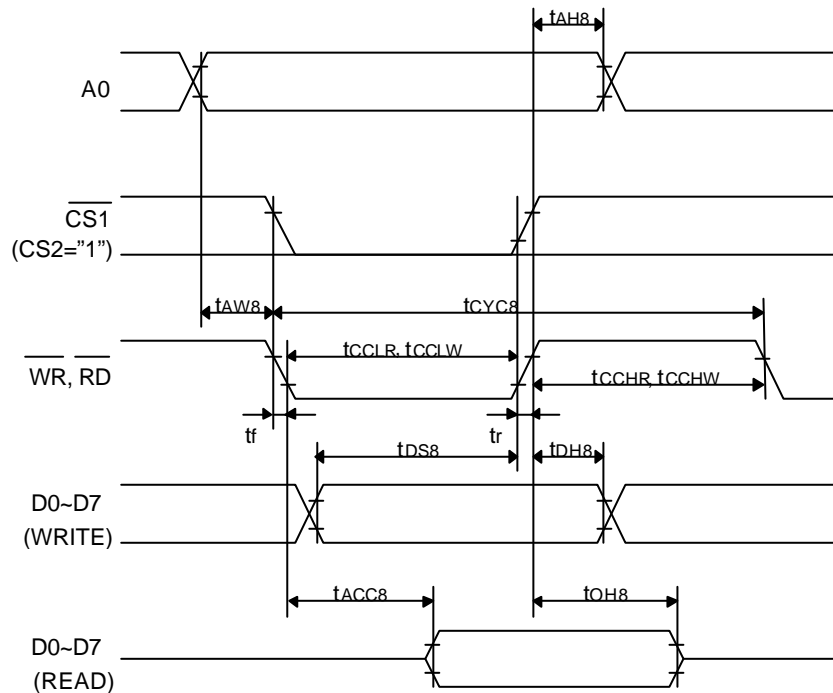

### 2.3.2. Read/Write Operation Sequence (68 series CPU)

$V_{DD}=5.0V\pm 10\%$

Parameter	Symbol	Min.	Max.	Units	
Address Setup Time	$t_{AH6}$	0	-	ns	
Address Hold Time	$t_{AW6}$	0	-	ns	
System Cycle Time	$t_{CYC6}$	166	-	ns	
Data Setup Time	$t_{DS6}$	30	-	ns	
Data Hold Time	$t_{DH6}$	10	-	ns	
Access Time (CL=100pF)	$t_{ACC6}$	-	70	ns	
Output Disable Time	$t_{OH6}$	10	50	ns	
Enable High Pulse Width	READ	$t_{EWHR}$	70	-	ns
	WRITE	$t_{EWHW}$	30	-	ns
Enable Low Pulse Width	READ	$t_{EWLR}$	30	-	ns
	WRITE	$t_{EWLW}$	30	-	ns

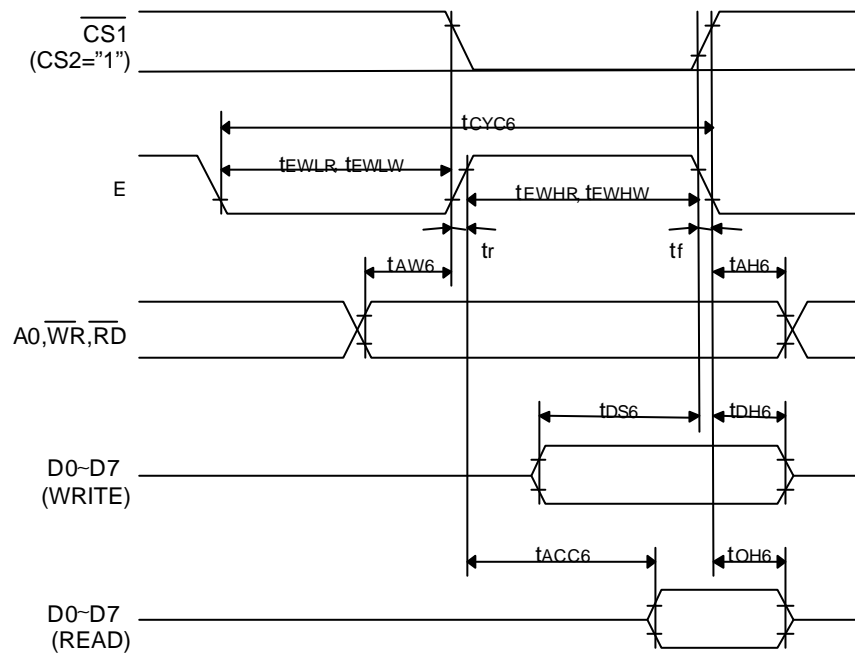

### 2.3.3. Serial Interface Sequence

$V_{DD}=5.0\pm 10\%$

Parameter	Symbol	Min.	Max.	Units
Serial Clock Cycle Time	$t_{SCYC}$	200	-	ns
Serial Clock High Pulse Width	$t_{SHW}$	75	-	ns
Serial Clock Low Pulse Width	$t_{SLW}$	75	-	ns
Address Setup Time	$t_{SAS}$	50	-	ns
Address Hold Time	$t_{SAH}$	100	-	ns
Data Setup Time	$t_{SDS}$	50	-	ns
Data Hold Time	$t_{SDH}$	50	-	ns
Chip Select Setup Time	$t_{CSS}$	100	-	ns
Chip Select Hold Time	$t_{CSH}$	100	-	ns

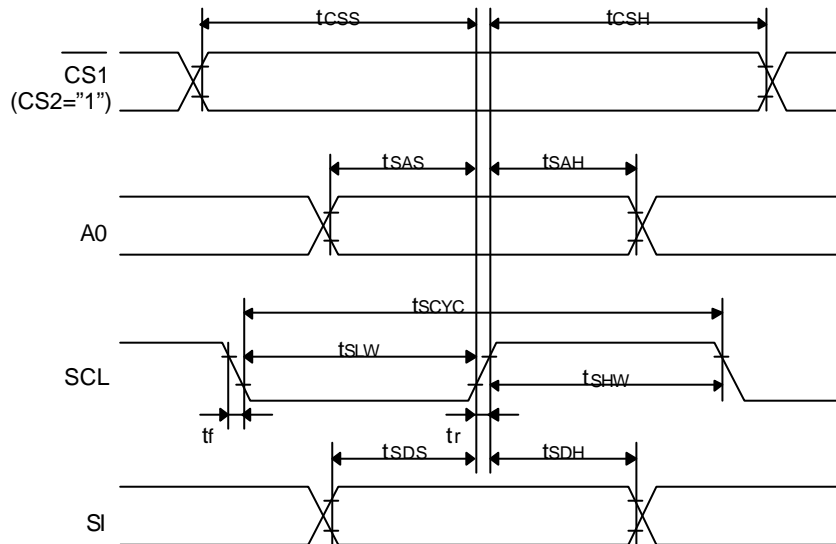

### 2.3.4. Display Control Timing Characteristics

#### Reset Input Timing

$V_{DD}=5.0\pm 10\%$

Parameter	Symbol	Min.	Typ.	Max.	Units
Reset time	$t_R$	-	-	0.5	$\mu s$
Reset "L" Pulse Width	$t_{RW}$	0.5	-	-	

#### Output Timing

$V_{DD}=5.0\pm 10\%$

Parameter	Symbol	Min.	Typ.	Max.	Units
FR Delay Time	$t_{DFR}$	-	10	40	ns

Note 1 :Valid only when the master mode is selected.

Note 2:All timing is based on 20% and 80% of  $V_{SS}$ .

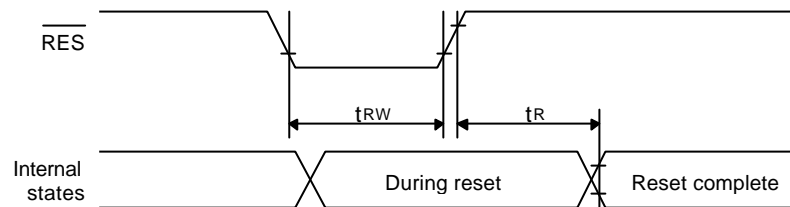

## Instruction Setup: Reference (reference)

### (1) Initialization

Note: With this IC, when the power is applied, LCD driving non-selective potentials V<sub>2</sub> and V<sub>3</sub> (SEG pin) and V<sub>1</sub> and V<sub>4</sub> (COM pin) are output through the LCD driving output pins SEG and COM. When electric charge is remaining in the smoothing capacitor connecting between the LCD driving voltage output pins (V<sub>1</sub> ~ V<sub>5</sub>) and the V<sub>DD</sub> pin, the picture on the display may become totally dark instantaneously when the power is turned on. To avoid occurrence of such a failure, we recommend the following flow when turning on the power.

① When the built-in power is being used immediately after turning on the power:

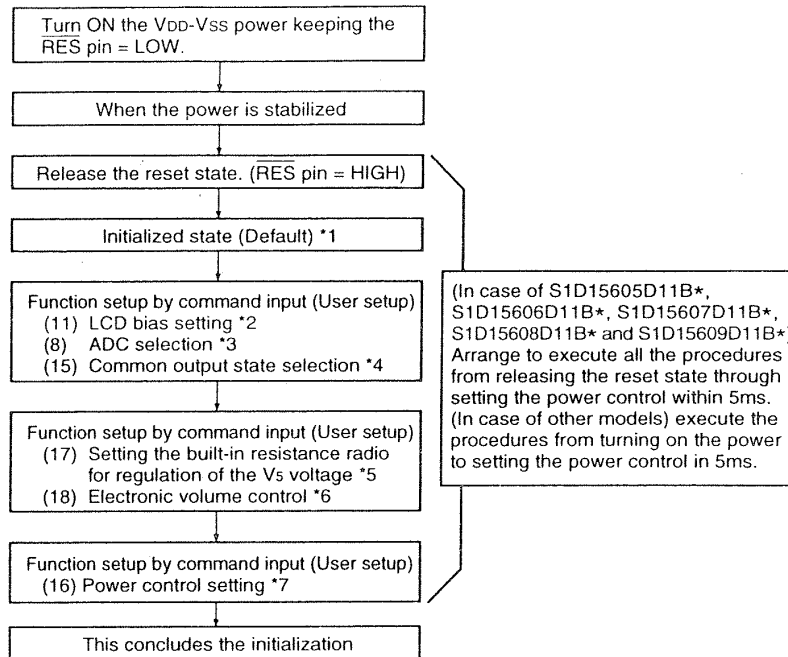

② When the built-in power is not being used immediately after turning on the power:

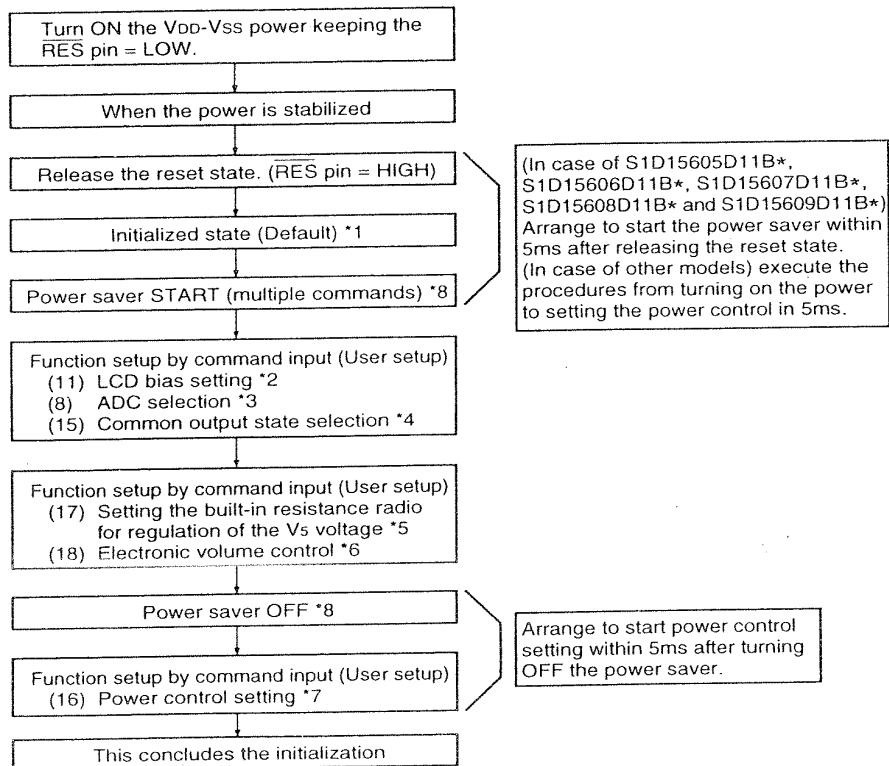

\* The target time of 5ms will result to vary depending on the panel characteristics and the capacitance of the smoothing capacitor. Therefore, we suggest you to conduct an operation check using the actual equipment.

Notes: Refer to respective sections or paragraphs listed below.

- \*1: 6. Description of functions; "Resetting circuit" (The contents of DDRAM can be variable even in the initial setting (Default) at the reset state.)
- \*2: 7. Command description; "(11) LCD bias setting"
- \*3: 7. Command description; "(8) ADC selection"
- \*4: 7. Command description; "(15) Common output state selection"
- \*5: 6. Description of functions; "Power circuit" & "(17) Command description; Setting the built-in resistance ratio for regulation of the V5 voltage"
- \*6: 6. Description of functions; "Power circuit" & "(18) Command description; Electronic volume control"
- \*7: 6. Description of functions; "Power circuit" & "(16) Command description; Power control setting"
- \*8: 7. The power saver ON state can either be in sleep state or stand-by state.  
Command description; "Power saver START (multiple commands)"

(2) Data Display

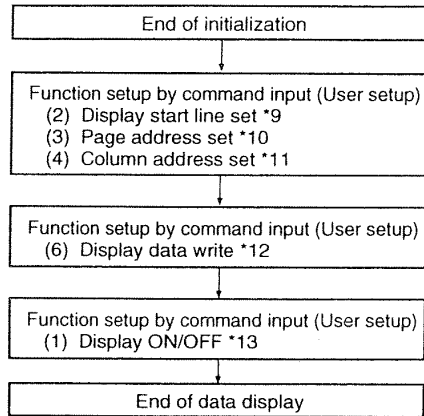

Notes: Reference items

- \*9: Command Description; Display start line set
- \*10: Command Description; Page address set
- \*11: Command Description; Column address set
- \*12: Command Description; Display data write
- \*13: Command Description; Display ON/OFF  
Avoid displaying all the data at the data display start (when the display is ON) in white.

(3) Power OFF \*14

- In case of S1D15605D11B\*, S1D15606D11B\*, S1D15607D11B\*, S1D15608D11B\* and S1D15609D11B\*,

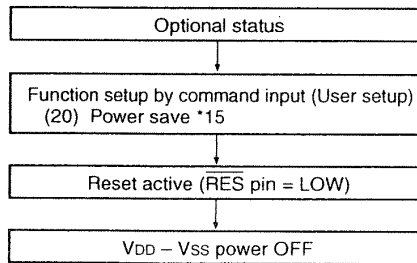

Set the time ( $t_L$ ) from reset active to turning off the VDD - VSS power ( $V_{DD} - V_{SS} = 1.8\text{ V}$ ) longer than the time ( $t_H$ ) when the potential of  $V_5 \sim V_1$  becomes below the threshold voltage (approximately 1 V) of the LCD panel. For  $t_H$ , refer to the <Reference Data> of this event. When  $t_H$  is too long, insert a resistor between  $V_5$  and VDD to reduce it.

- In case of other models,

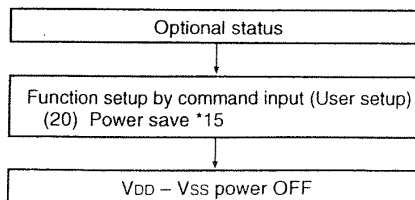

Set the time ( $t_L$ ) from power save to turning off the VDD - VSS power ( $V_{DD} - V_{SS} = 1.8\text{ V}$ ) longer than the time ( $t_H$ ) when the potential of  $V_5 \sim V_1$  becomes below the threshold voltage (approximately 1V) of the LCD panel.

- $t_H$  is determined depending on the voltage regulator external resistors  $R_a$  and  $R_b$  and the time constant of  $V_5 \sim V_1$  smoothing capacity  $C_2$ .
- When an internal resistor is used, it is recommended to insert a resistor R between VDD and  $V_5$  to reduce  $t_H$ .

Notes: Reference items

- \*14: The logic circuit of this IC's power supply VDD - VSS controls the driver of the LCD power supply VDD - V5. So, if the power supply VDD - VSS is cut off when the LCD power supply VDD - V5 has still any residual voltage, the driver (COM. SEG) may output any uncontrolled voltage. When turning off the power, observe the following basic procedures:
  - After turning off the internal power supply, make sure that the potential  $V_5 \sim V_1$  has become below the threshold voltage of the LCD panel, and then turn off this IC's power supply (VDD - VSS).  
6. Description of Function, 6.7 Power Circuit
- \*15: After inputting the power save command, be sure to reset the function using the  $\overline{\text{RES}}$  terminal until the power supply VDD - VSS is turned off. 7. Command Description (20) Power\_Save
- \*16: After inputting the power save command, do not reset the function using the RES terminal until the power supply VDD - VSS is turned off. 7. Command Description (20) Power Save

(4) Refresh

It is recommended that the operating modes and display contents be refreshed periodically to prevent the effect of unexpected noise.

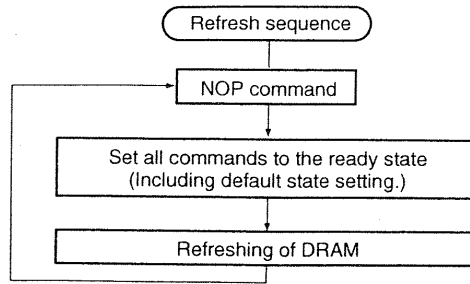

## 2.4. Lighting Specifications

### 2.4.1. Absolute Maximum Ratings

Ta=25°C (1Unit)

Parameter	Symbol	Conditions	Min.	Typ.	Max.	Units
Foward Current	I <sub>F</sub>	Note 1	-	-	75	mA
Reverse Voltage	V <sub>R</sub>	-	-	-	8	V
LED Power Dissipation	P <sub>D</sub>	-	-	-	0.375	W

Note 1 : Refer to the foward current derating curve.

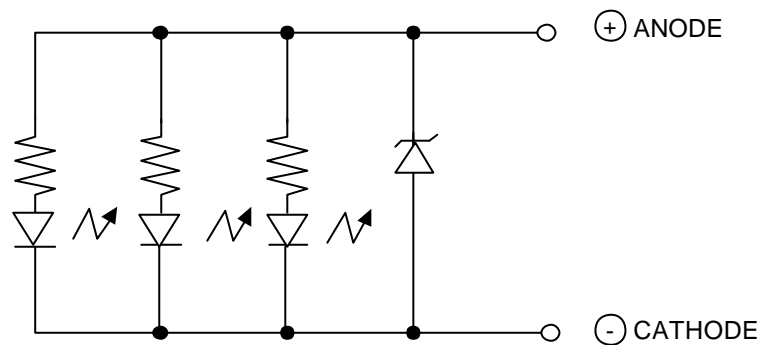
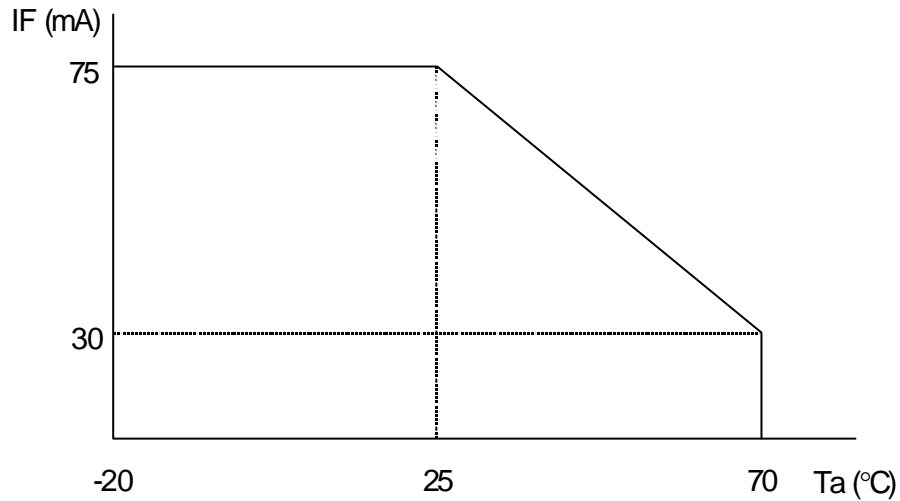

### 2.4.2. Operating Characteristics

Ta=25°C

Parameter	Symbol	Conditions	Min.	Typ.	Max.	Units
Foward Voltage	V <sub>F</sub>	I <sub>F</sub> =40mA	-	5.0	-	V
Luminance of Backlight Surface	L	I <sub>F</sub> =40mA	65	100	-	cd/m <sup>2</sup>

### 3. Optical Specifications

#### 3.1. LCD Driving Voltage

Parameter	Symbol	Conditions	Min.	Typ.	Max.	Units
Recommended LCD Driving Voltage Note 1	$V_{DD}-V_5$	$T_a = -20^\circ\text{C}$	-	-	9.1	V
		$T_a = 25^\circ\text{C}$	7.8	8.5	9.1	V
		$T_a = 70^\circ\text{C}$	7.4	-	-	V

Note 1 : Voltage (Applied actual waveform to LCD Module) for the best contrast. The range of minimum and maximum shows tolerance of the operating voltage. The specified contrast ratio and response time are not guaranteed over the entire range.

#### 3.2. Optical Characteristics

$T_a = 25^\circ\text{C}$ , 1/65 Duty, 1/7 Bias,  $V_{OD} = 8.5\text{V}$  (Note 4),  $\theta = 0^\circ$ ,  $\phi = -^\circ$

Parameter	Symbol	Conditions	Min.	Typ.	Max.	Units
Contrast Ratio Note 1	CR	$\theta = 0^\circ$ , $\phi = -^\circ$	-	8	-	
Viewing Angle		Shown in 3.3				
Response Time	Rise Note 2	$T_{ON}$	-	160	240	ms
	Decay Note 3	$T_{OFF}$	-	190	290	ms

Note 1 : Contrast ratio is defined as follows. ( $CR = L_{ON} / L_{OFF}$ )

$L_{ON}$  : Luminance of the ON segments

$L_{OFF}$  : Luminance of the OFF segments

Mesuring Spot :  $3\text{mm}\phi$

Note 2 : The time that the luminance level reaches 90% of the saturation level from 0% when ON signal is applied.

Note 3 : The time that the luminance level reaches 10% of the saturation level from 100% when OFF signal is applied.

Note 4 : Definition of Driving Voltage  $V_{OD}$

$$V_{OD} = V_{CC} - V_{ADJ} - V_{BE}$$

Assuming that the typical driving waveforms shown below are applied to the LCD Panel at 1/A Duty - 1/B Bias (A: Duty Number, B: Bias Number). Driving voltage

$V_{OD}$  is defined as the voltage  $V_{O-P}$  when the contrast ratio ( $CR = L_{ON} / L_{OFF}$ ) is at its maximum.

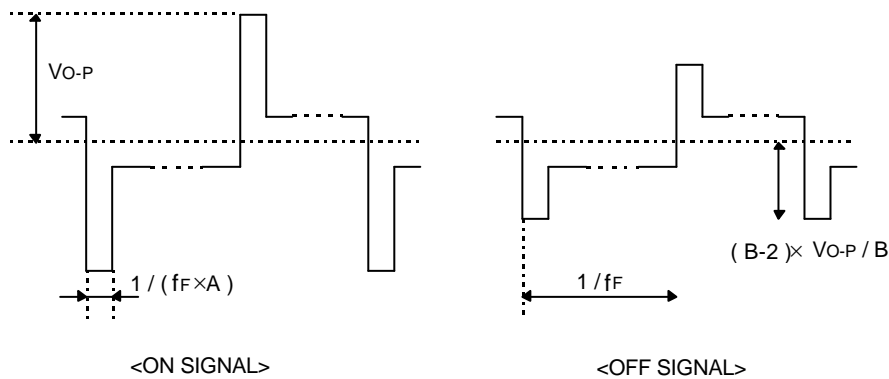

### 3.3. Definition of Viewing Angle and Optimum Viewing Area

\*Point ● shows the point where contrast ratio is measured. :  $\theta = 0^\circ$ ,  $\phi = 0^\circ$

\*Driving condition: 1/65 Duty, 1/7 Bias,  $V_{OD}=8.5V$ ,  $f_F=84.6Hz$

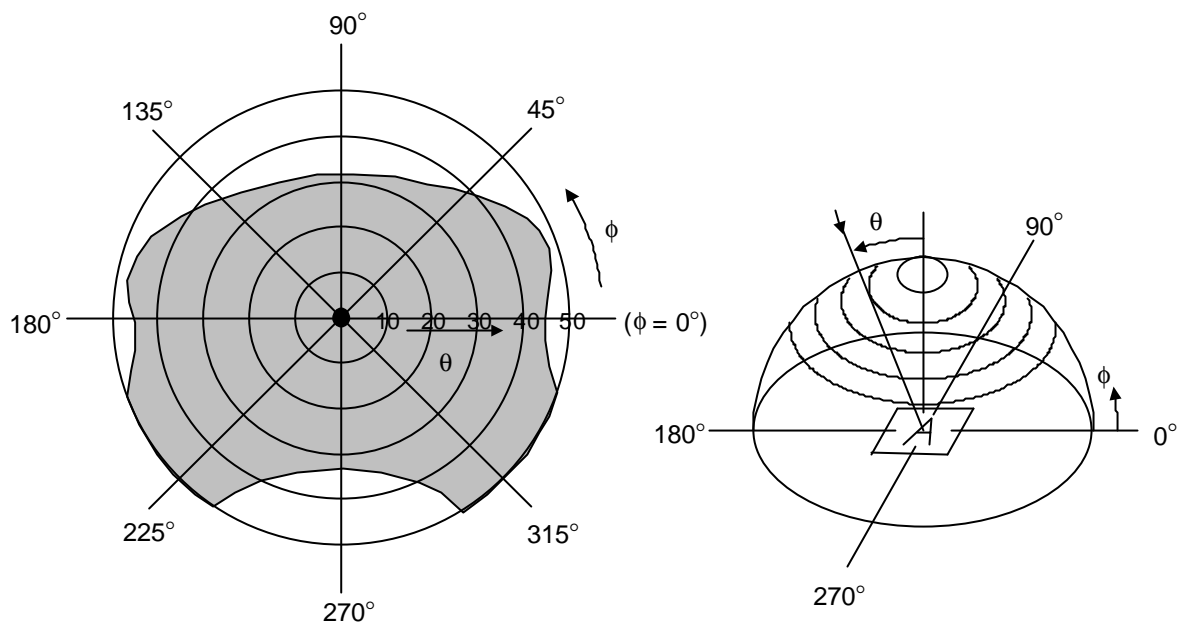

\*Area  shows typ.  $CR \geq 3$  (Measuring Spot :  $3mm\phi$ )

### 3.4. System Block Diagram

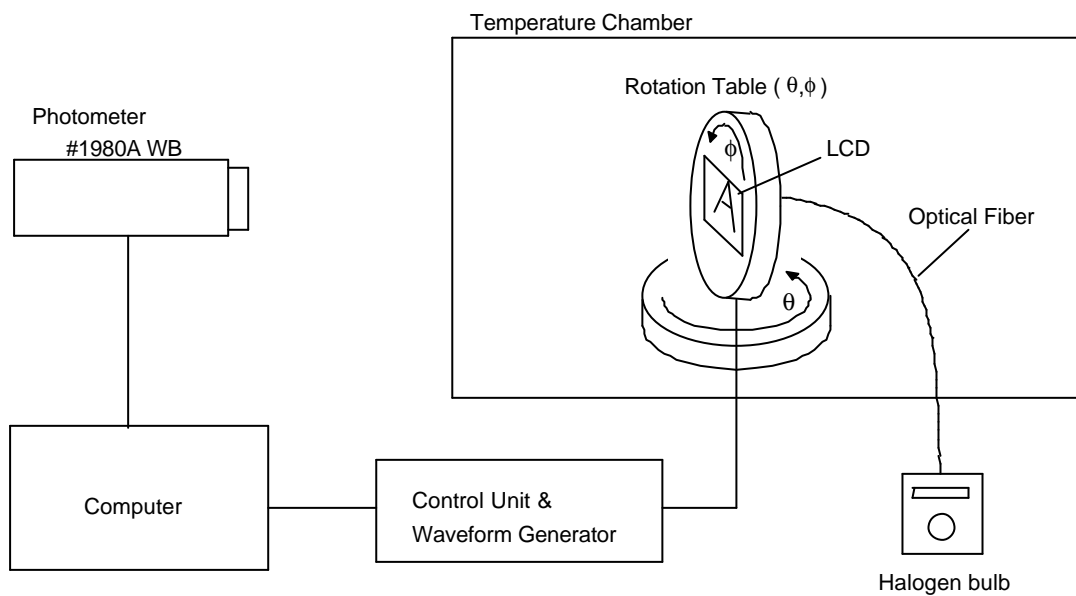

## 4.I/O Terminal

### 4.1.Pin Assignment

#### CN1

No.	Symbol	Function
1	$\overline{\text{CS1}}$	Chip Select Signal L : Active
2	$\overline{\text{RES}}$	Reset Signal L : Reset
3	A0	H : D0~D7 are Display Data L : D0~D7 are Instructions
4	$\overline{\text{WR}}$	Write Signal L : Active
5	$\overline{\text{RD}}$	Read Signal L : Active
6	D0	Data Bus Line
7	D1	Data Bus Line
8	D2	Data Bus Line
9	D3	Data Bus Line
10	D4	Data Bus Line
11	D5	Data Bus Line
12	D6	Data Bus Line
13	D7	Data Bus Line
14	V <sub>DD</sub>	Power Supply for Logic
15	GND	Power Supply ( 0V, GND )
16	V <sub>OUT</sub>	DC/DC Voltage Converter Output
17	CAP3-	DC/DC Voltage Converter Negative Connection
18	CAP1+	DC/DC Voltage Converter Positive Connection
19	CAP1-	DC/DC Voltage Converter Negative Connection
20	CAP2-	DC/DC Voltage Converter Negative Connection
21	CAP2+	DC/DC Voltage Converter Positive Connection
22	V <sub>1</sub>	Power Supply for LCD Drive V <sub>1</sub> = 1/7, V <sub>5</sub>
23	V <sub>2</sub>	Power Supply for LCD Drive V <sub>2</sub> = 2/7, V <sub>5</sub>
24	V <sub>3</sub>	Power Supply for LCD Drive V <sub>3</sub> = 5/7, V <sub>5</sub>
25	V <sub>4</sub>	Power Supply for LCD Drive V <sub>4</sub> = 6/7, V <sub>5</sub>
26	V <sub>5</sub>	Power Supply for LCD Drive V <sub>5</sub> , V <sub>OUT</sub>
27	VR	Voltage Adjustment Pin
28	C86	Interface Mode Select Signal H : 68 series L : 80 series
29	P/S	Parallel / Serial Data Select Signal H: Parallel L: Serial
30	IRS	This terminal selects the resistors for the V <sub>5</sub> voltage level adjustment. IRS="H" :Use the internal resistors IRS="L" :Do not use the internal resistors. The V <sub>5</sub> voltage level is regulated by an external resistive voltage divider attached to the VR terminal.

## 4.2. Example of Power Supply

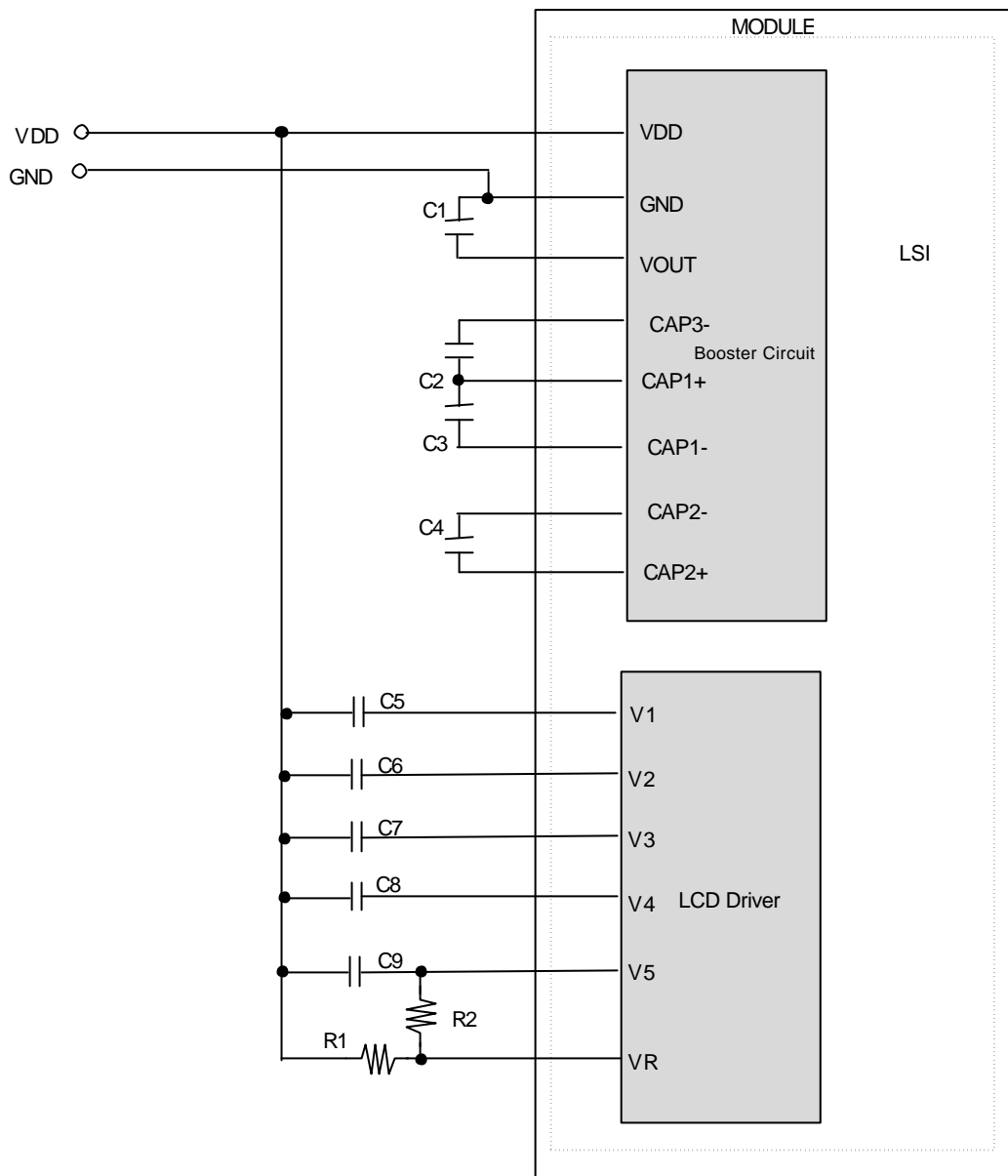

### 4.3. Block Diagram

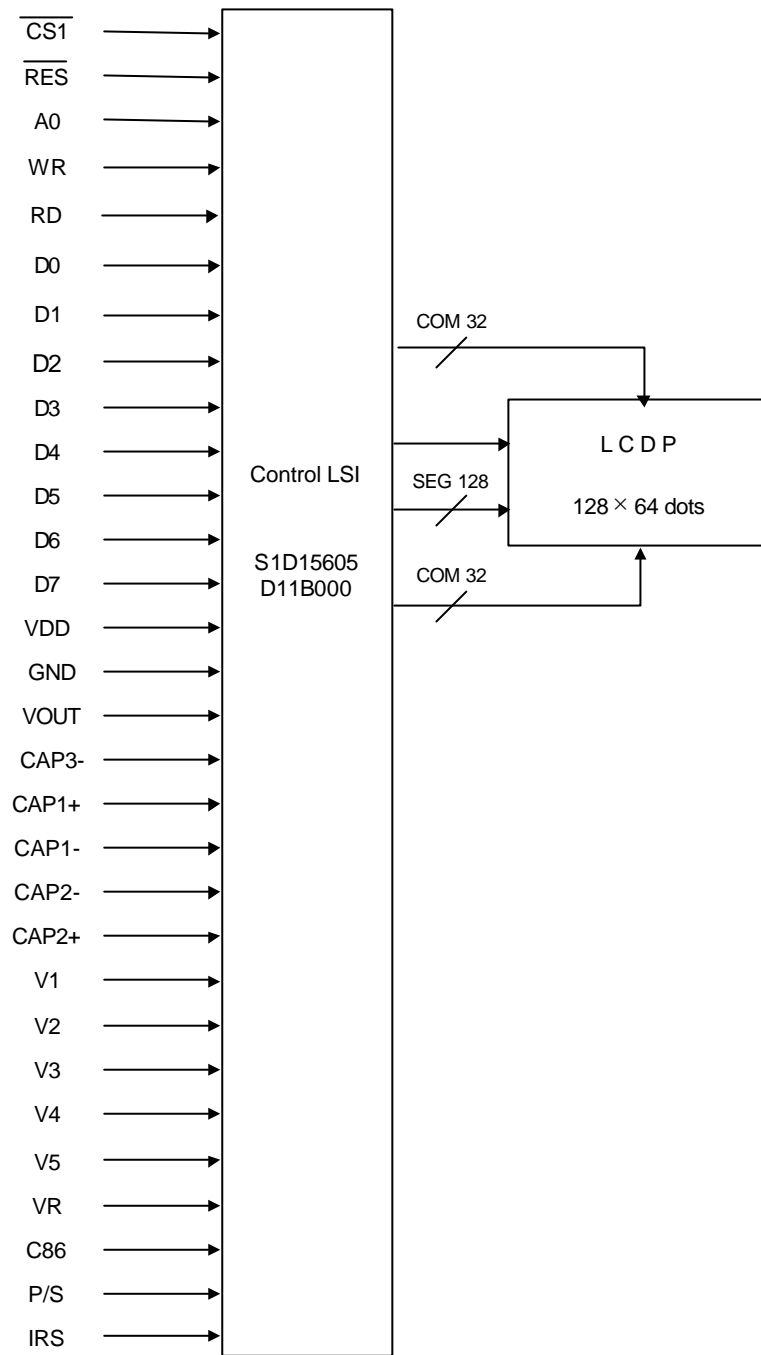

## 5. Test

No change on display and in operation under the following test condition.

Conditions: Unless otherwise specified, tests will be conducted under the following condition.

Temperature:  $20 \pm 5^\circ\text{C}$

Humidity :  $65 \pm 5\% \text{RH}$

tests will be not conducted under functioning state.

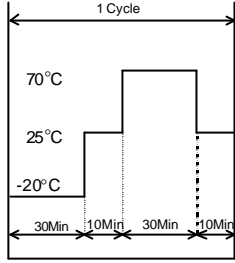
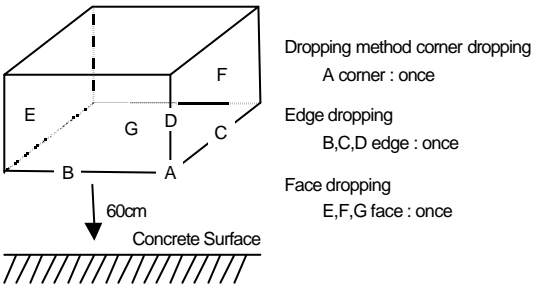
No.	Parameter	Conditions	Notes
1	High Temperature Operating	$70^\circ\text{C} \pm 2^\circ\text{C}$ , 96hrs (operation state)	
2	Low Temperature Operating	$-20^\circ\text{C} \pm 2^\circ\text{C}$ , 96hrs (operation state)	1
3	High Temperature Storage	$85^\circ\text{C} \pm 2^\circ\text{C}$ , 96hrs	2
4	Low Temperature Storage	$-30^\circ\text{C} \pm 2^\circ\text{C}$ , 96hrs	1,2
5	Damp Proof Test	$40^\circ\text{C} \pm 2^\circ\text{C}$ , 90~95%RH, 96hrs	1,2
6	Temperature Cycle Test	5 Cycle  <p>The function test shall be conducted after 1 hours storage at the normal temperature and humidity after removed from the test chamber.</p>	1
7	Shock Test	To be measured after dropping from 60cm high on the concrete surface in packing state. 	

Note 1 :No dew condensation to be observed.

Note 2 :The function test shall be conducted after 4 hours storage at the normal Temperature and humidity after removed from the test chamber.

Note 3 :Vibration test will be conducted to the product itself without putting it in a container.

## 6.Appearance Standards

### 6.1.Inspection conditions

The LCD shall be inspected under 40W white fluorescent light.

The distance between the eyes and the sample shall be more than 30cm.

All directions for inspecting the sample should be within 45°against perpendicular line.

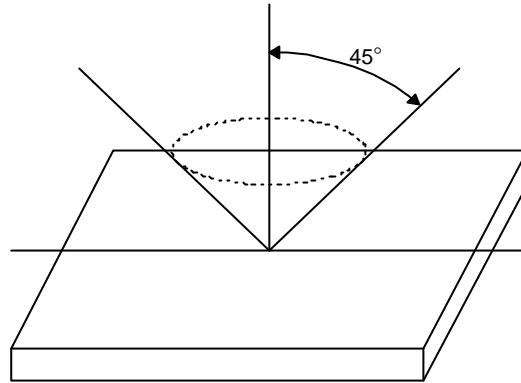

### 6.2.Definition of applicable Zones

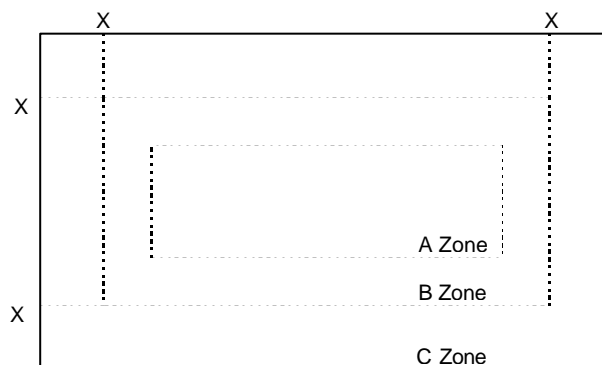

X : Maximum Seal Line

A Zone : Active display area

B Zone : Out of active display area ~ Maximum seal line

C Zone : Rest parts

A Zone + B Zone = Validity viewing area

6.3.Standards(middle scale, LED)

D = ( Long + Short ) / 2 \* : Disregard Units : mm

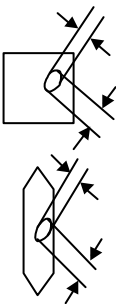
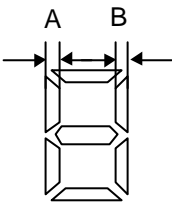
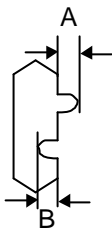
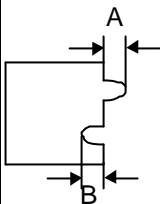
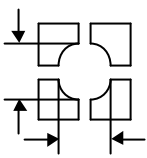
No.	Parameter	Criteria																										
1	The Shape of Dot	<p>(1) Pin Hole</p>  <table border="1" data-bbox="756 322 1383 515"> <thead> <tr> <th>Dimension</th> <th>Acceptable Number</th> </tr> </thead> <tbody> <tr> <td><math>D \leq 0.10</math></td> <td>*</td> </tr> <tr> <td><math>0.10 &lt; D \leq 0.20</math></td> <td>1 pc / dot(only segment)or less 5 pcs / cell or less</td> </tr> </tbody> </table> <p>(2) Pattern Shift</p>  <p><math> A - B  \leq 0.15</math></p> <p>(3) Breakage or Chips / Deformation</p> <p>1.Segment Type</p>  <table border="1" data-bbox="756 1039 1383 1184"> <thead> <tr> <th>Dimension</th> <th>Acceptable Number</th> </tr> </thead> <tbody> <tr> <td><math>A \leq 0.10</math></td> <td>*</td> </tr> <tr> <td><math>B \leq 0.15</math></td> <td>*</td> </tr> </tbody> </table> <p>2.Dot Type</p>  <table border="1" data-bbox="756 1279 1383 1615"> <thead> <tr> <th>Dimension</th> <th>Acceptable Number</th> </tr> </thead> <tbody> <tr> <td><math>A \leq 0.10</math></td> <td>* (Should not be connected to next dot)</td> </tr> <tr> <td><math>0.10 &lt; A \leq 0.15</math></td> <td>1 pc / dot(only segment)or less 5 pcs / cell or less (Should not be connected to next dot)</td> </tr> <tr> <td><math>B \leq 0.15</math></td> <td>*</td> </tr> </tbody> </table> <p>3.Defective type extends over multiple numbers of dots</p>  <table border="1" data-bbox="756 1711 1383 1995"> <thead> <tr> <th>Dimension</th> <th>Acceptable Number</th> </tr> </thead> <tbody> <tr> <td><math>D \leq 0.10</math></td> <td>*</td> </tr> <tr> <td><math>0.10 &lt; D \leq 0.20</math></td> <td>1 pc / dot(only segment)or less 5 pcs / cell or less (Individual dot must secure 1/2 area or more)</td> </tr> </tbody> </table>	Dimension	Acceptable Number	$D \leq 0.10$	*	$0.10 < D \leq 0.20$	1 pc / dot(only segment)or less 5 pcs / cell or less	Dimension	Acceptable Number	$A \leq 0.10$	*	$B \leq 0.15$	*	Dimension	Acceptable Number	$A \leq 0.10$	* (Should not be connected to next dot)	$0.10 < A \leq 0.15$	1 pc / dot(only segment)or less 5 pcs / cell or less (Should not be connected to next dot)	$B \leq 0.15$	*	Dimension	Acceptable Number	$D \leq 0.10$	*	$0.10 < D \leq 0.20$	1 pc / dot(only segment)or less 5 pcs / cell or less (Individual dot must secure 1/2 area or more)
Dimension	Acceptable Number																											
$D \leq 0.10$	*																											
$0.10 < D \leq 0.20$	1 pc / dot(only segment)or less 5 pcs / cell or less																											
Dimension	Acceptable Number																											
$A \leq 0.10$	*																											
$B \leq 0.15$	*																											
Dimension	Acceptable Number																											
$A \leq 0.10$	* (Should not be connected to next dot)																											
$0.10 < A \leq 0.15$	1 pc / dot(only segment)or less 5 pcs / cell or less (Should not be connected to next dot)																											
$B \leq 0.15$	*																											
Dimension	Acceptable Number																											
$D \leq 0.10$	*																											
$0.10 < D \leq 0.20$	1 pc / dot(only segment)or less 5 pcs / cell or less (Individual dot must secure 1/2 area or more)																											

$$D = ( \text{Long} + \text{Short} ) / 2 \quad * : \text{Disregard} \quad \text{Units : mm}$$

No.	Parameter	Criteria																																										
2	Black and White Spots, Foreign Substances	<p>(1) Round Shape</p> <table border="1"> <thead> <tr> <th rowspan="2">Dimension \ Zone</th> <th colspan="3">Acceptable Number</th> </tr> <tr> <th>A</th> <th>B</th> <th>C</th> </tr> </thead> <tbody> <tr> <td><math>D \leq 0.10</math></td> <td>*</td> <td>*</td> <td>*</td> </tr> <tr> <td><math>0.10 &lt; D \leq 0.20</math></td> <td>6</td> <td>6</td> <td>*</td> </tr> <tr> <td><math>0.20 &lt; D \leq 0.30</math></td> <td>4</td> <td>4</td> <td>*</td> </tr> </tbody> </table> <p>Individual dot must secure 1/2 area or more.</p> <p>(2) Line Shape</p> <table border="1"> <thead> <tr> <th rowspan="2">Length \ Width \ Zone</th> <th colspan="3">Acceptable Number</th> </tr> <tr> <th>A</th> <th>B</th> <th>C</th> </tr> </thead> <tbody> <tr> <td>* \ <math>W \leq 0.03</math></td> <td>*</td> <td>*</td> <td>*</td> </tr> <tr> <td><math>L \leq 2.0</math> \ <math>0.03 &lt; W \leq 0.05</math></td> <td>5</td> <td>5</td> <td>*</td> </tr> <tr> <td><math>L \leq 1.0</math> \ <math>\leq 0.10</math></td> <td>4</td> <td>4</td> <td>*</td> </tr> <tr> <td>* \ <math>0.10 &lt; W</math></td> <td colspan="2">In the same way (1)</td> <td>*</td> </tr> </tbody> </table> <p>No more than 9pcs as total. (Refer to "Complex Foreign Substance Defects")</p>	Dimension \ Zone	Acceptable Number			A	B	C	$D \leq 0.10$	*	*	*	$0.10 < D \leq 0.20$	6	6	*	$0.20 < D \leq 0.30$	4	4	*	Length \ Width \ Zone	Acceptable Number			A	B	C	* \ $W \leq 0.03$	*	*	*	$L \leq 2.0$ \ $0.03 < W \leq 0.05$	5	5	*	$L \leq 1.0$ \ $\leq 0.10$	4	4	*	* \ $0.10 < W$	In the same way (1)		*
Dimension \ Zone	Acceptable Number																																											
	A	B	C																																									
$D \leq 0.10$	*	*	*																																									
$0.10 < D \leq 0.20$	6	6	*																																									
$0.20 < D \leq 0.30$	4	4	*																																									
Length \ Width \ Zone	Acceptable Number																																											
	A	B	C																																									
* \ $W \leq 0.03$	*	*	*																																									
$L \leq 2.0$ \ $0.03 < W \leq 0.05$	5	5	*																																									
$L \leq 1.0$ \ $\leq 0.10$	4	4	*																																									
* \ $0.10 < W$	In the same way (1)		*																																									
3	Color Variation	Not to be conspicuous defects.																																										
4	Air Bubbles (between glass & polarizer)	<table border="1"> <thead> <tr> <th rowspan="2">Dimension \ Zone</th> <th colspan="3">Acceptable Number</th> </tr> <tr> <th>A</th> <th>B</th> <th>C</th> </tr> </thead> <tbody> <tr> <td><math>D \leq 0.30</math></td> <td>*</td> <td>*</td> <td>*</td> </tr> <tr> <td><math>0.30 &lt; D \leq 0.40</math></td> <td>3</td> <td>*</td> <td>*</td> </tr> <tr> <td><math>0.40 &lt; D \leq 0.60</math></td> <td>2</td> <td>3</td> <td>*</td> </tr> </tbody> </table> <p>No more than 3pcs as total. (Refer to "Complex Foreign Substance Defects")</p>	Dimension \ Zone	Acceptable Number			A	B	C	$D \leq 0.30$	*	*	*	$0.30 < D \leq 0.40$	3	*	*	$0.40 < D \leq 0.60$	2	3	*																							
Dimension \ Zone	Acceptable Number																																											
	A	B	C																																									
$D \leq 0.30$	*	*	*																																									
$0.30 < D \leq 0.40$	3	*	*																																									
$0.40 < D \leq 0.60$	2	3	*																																									
5	Polarizer Scratches	Not to be conspicuous defects.																																										
6	Polarizer Dirts	If the stains are removed easily from LCDP surface, the module is not defective.																																										
7	Complex Foreign Substance Defects	Black spots, line shaped foreign substances or air bubbles between glass & polarizer should be 9pcs maximum in total.																																										
8	Distance between Different Foreign Substance Defects	20mm or more																																										

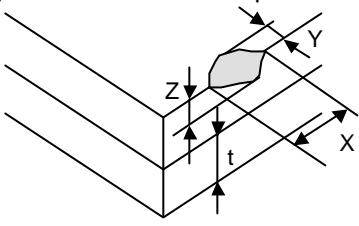
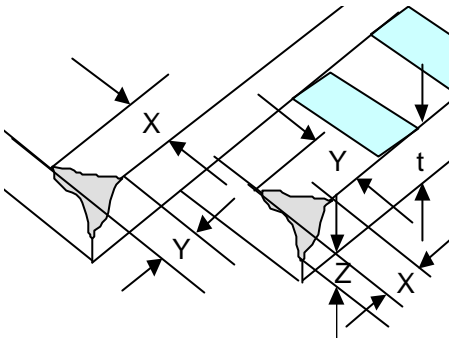
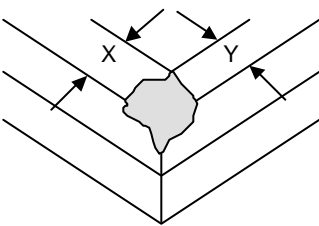
No.	Parameter	Criteria												
11	Chipped Glass	<p>(1) Other than electrode pad areas and corner areas</p>  <table border="1" data-bbox="986 380 1385 481"> <thead> <tr> <th>X</th> <th>Y</th> <th>Z</th> </tr> </thead> <tbody> <tr> <td>≤10.0</td> <td>≤1.5</td> <td>≤t</td> </tr> </tbody> </table> <p>(2) Corner Areas</p> <p>1. Lead Areas</p>  <table border="1" data-bbox="587 1003 1385 1146"> <thead> <tr> <th>X</th> <th>Y</th> <th>Z</th> </tr> </thead> <tbody> <tr> <td>Half dimension till first Leads terminal</td> <td>Same as terminal width</td> <td>*</td> </tr> </tbody> </table> <p>It is allowed 1 chip as total length of Z sirection                      In case of 2 or more chips, <math>Z \leq 1/2t</math></p> <p>2. Other than electrode pad Areas</p>  <p><math>X+Y \leq 8.0</math></p> <p>If the chipped area touches the seal line, the LCD is not acceptable.</p>	X	Y	Z	≤10.0	≤1.5	≤t	X	Y	Z	Half dimension till first Leads terminal	Same as terminal width	*
X	Y	Z												
≤10.0	≤1.5	≤t												
X	Y	Z												
Half dimension till first Leads terminal	Same as terminal width	*												

## 7.Code System of Production Lot

The production lot of module is specified as follows.

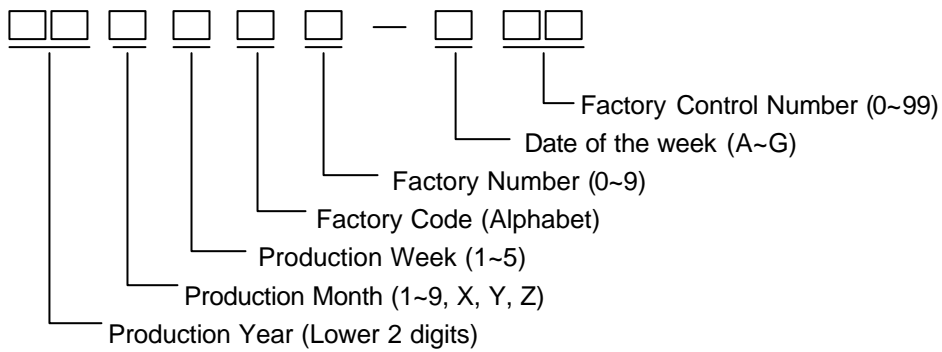

## 8.Type Number

The type number of module is specified as follows.

F-51553GNBJ-LW-AB

## 9.Applying Precautions

Please contact us when questions and/or new problems not specified in this Specifications arise.

## 10.Precautions Relating Product Handling

The Following precautions will guide you in handling our product correctly.

- 1) Liquid crystal display devices
  1. The liquid crystal display device panel used in the liquid crystal display module is made of plate glass. Avoid any strong mechanical shock. Should the glass break handle it with care.
  2. The polarizer adhering to the surface of the LCD is made of a soft material. Guard against scratching it.
- 2) Care of the liquid crystal display module against static electricity discharge.
  1. When working with the module, be sure to ground your body and any electrical equipment you may be using. We strongly recommend the use of anti static mats ( made of rubber ), to protect work tables against the hazards of electrical shock.
  2. Avoid the use of work clothing made of synthetic fibers. We recommend cotton clothing or other conductivity-treated fibers.
  3. Slowly and carefully remove the protective film from the LCD module, since this operation can generate static electricity.
- 3) When the LCD module alone must be stored for long periods of time:
  1. Protect the modules from high temperature and humidity.
  2. Keep the modules out of direct sunlight or direct exposure to ultraviolet rays.
  3. Protect the modules from excessive external forces.
- 4) Use the module with a power supply that is equipped with an overcurrent protector circuit,since the module is not provided with this protective feature.
- 5) Do not ingest the LCD fluid itself should it leak out of a damaged LCD module. Should hands or clothing come in contact with LCD fluid, wash immediately with soap.
- 6) Conductivity is not guaranteed for models that use metal holders where solder connections between the metal holder and the PCB are not used. Please contact us to discuss appropriate ways to assure conductivity.
- 7) For models which use CFL:
  1. High voltage of 1000V or greater is applied to the CFL cable connector area. Care should be taken not to touch connection areas to avoid burns.
  2. Protect CFL cables from rubbing against the unit and thus causing the wire jacket to become worn.
  3. The use of CFLs for extended periods of time at low temperatures will significantly shorten their service life.
- 8) For models which use touch panels:
  1. Do not stack up modules since they can be damaged by components on neighboring modules.
  2. Do not place heavy objects on top of the product. This could cause glass breakage.
- 9) For models which use COG,TAB,or COF:
  1. The mechanical strength of the product is low since the IC chip faces out unprotected from the rear. Be sure to protect the rear of the IC chip from external forces.
  2. Given the fact that the rear of the IC chip is left exposed, in order to protect the unit from electrical damage, avoid installation configurations in which the rear of the IC chip runs the risk of making any electrical contact.

- 10) Models which use flexible cable, heat seal, or TAB:
  1. In order to maintain reliability, do not touch or hold by the connector area.
  2. Avoid any bending, pulling, or other excessive force, which can result in broken connections.
  
- 11) have an adverse effect on connecting parts ( LCD panel-TCP / HEAT SEAL / FPC / etc., PCB-TCP / HEAT SEAL / FPC etc., TCP-HEAT SEAL, TCP-FPC, HEAT SEAL-FPC, etc.,) depending on its materials.  
Please check and evaluate these materials carefully before use.
  
- 12) In case of acrylic plate is attached to front side of LCD panel, cloudiness ( very small cracks ) can occur on acrylic plate, being influenced by some components generated from polarizer film..  
Please check and evaluate those acrylic materials carefully before use.

## 11.Warranty

This product has been manufactured to your company's specifications as a part for use in your company's general electronic products. It is guaranteed to perform according to delivery specifications. For any other use apart from general electronic equipment, we cannot take responsibility if the product is used in medical devices, nuclear power control equipment, aerospace equipment, fire and security systems, or any other applications in which there is a direct risk to human life and where extremely high levels of reliability are required. If the product is to be used in any of the above applications, we will need to enter into a separate product liability agreement.

1. We cannot accept responsibility for any defect, which may arise from additional manufacturing of the product (including disassembly and reassembly), after product delivery.
2. We cannot accept responsibility for any defect, which may arise after the application of strong external force to the product.
3. We cannot accept responsibility for any defect, which may arise due to the application of static electricity after the product has passed your company's acceptance inspection procedures.
4. When the product is in CFL models, CFL service life and brightness will vary According to the performance of the inverter used, leaks, etc. We cannot accept responsibility for product performance, reliability, or defect, which may arise.
5. We cannot accept responsibility for intellectual property of a third party, which may arise through the application of our product to your assembly with exception to those issues relating directly to the structure or method of manufacturing of our product.
6. Optrex will not be held responsible for any quality guarantee issue for defect products judged as Optrex-origin longer than 2 (two) years from Optrex production or 1(one) year from Optrex, Optrex America, Optrex Europe, delivery which ever comes later.